

# Construction Details

Construction details and specifications help the building department find problems before they occur in the field.

This example shows the types of detail our office will be looking for in your plan submittal.

**In addition to construction details such as these, you will need to submit details on:**

1. Foundation detail
2. Floor Plan

**REMINDER:**

Permits are only issued after plan review. The time required to conduct this review will depend on the completeness of the information we receive in the plans.

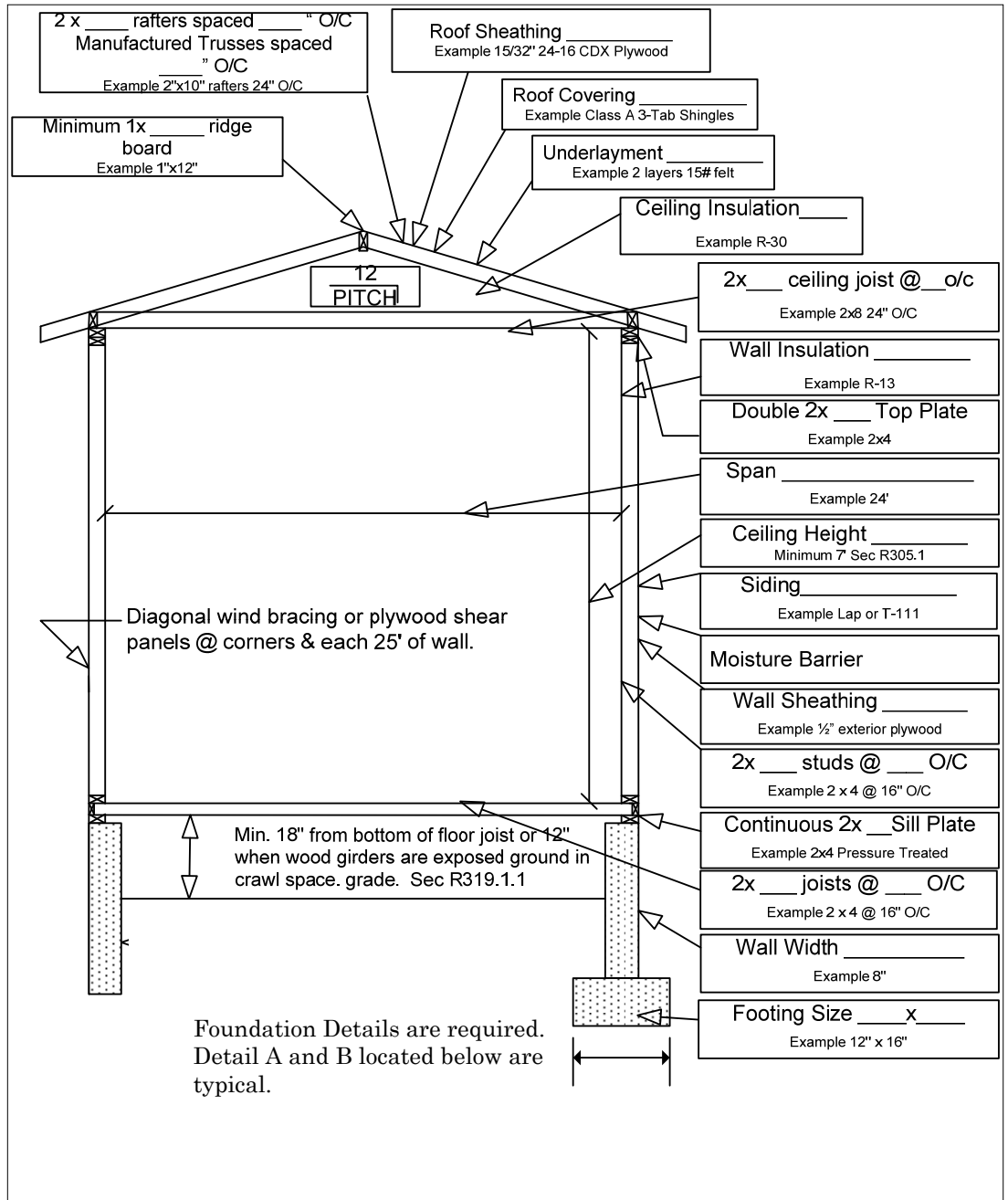

**Foundation Detail A**

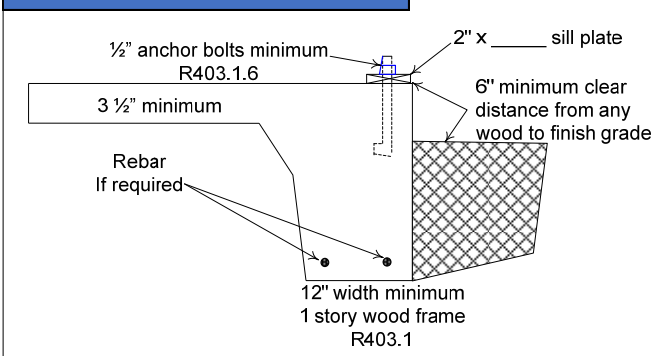

**Foundation Detail B**

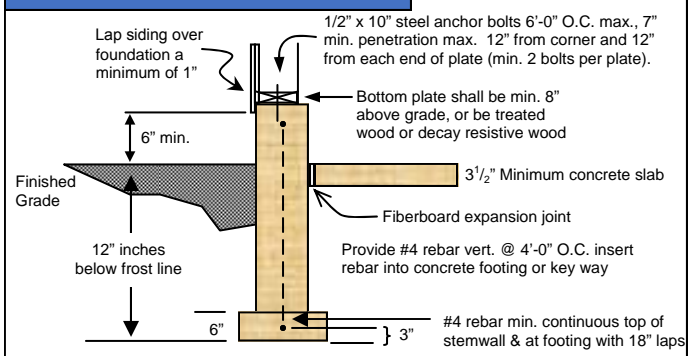

# Floor Plan

The floor plan is used to determine the complexity of the work and to validate the site plan. Floor plans must show any dimensions of the structure and openings.

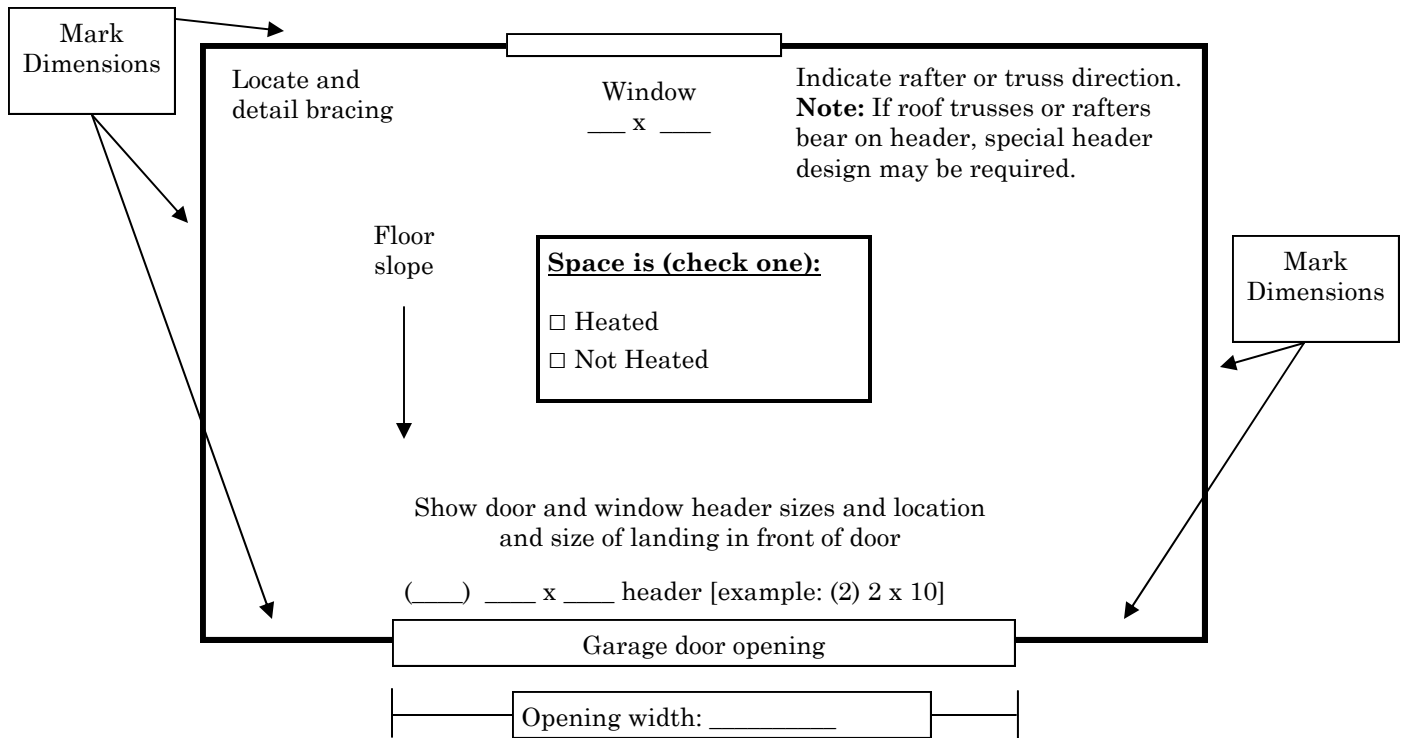

# Braced Wall Panel Detail

